

Stationary Livestock Scale

MAS-LC

Installation Manual



An ISO 9001 registered company
© Rice Lake Weighing Systems. All rights reserved.

Rice Lake Weighing Systems® is a registered trademark of
Rice Lake Weighing Systems.

All other brand or product names within this publication are trademarks or
registered trademarks of their respective companies.

All information contained within this publication is, to the best of our knowledge, complete and
accurate at the time of publication. Rice Lake Weighing Systems reserves the right to make
changes to the technology, features, specifications and design of the equipment without notice.

The most current version of this publication, software, firmware and all other product
updates can be found on our website:

www.ricelake.com

Contents

1.0	Introduction	1
1.1	Safety	1
1.2	Animal Safety	2
1.3	Calibration	2
1.4	Safety Decals	2
1.5	Overview	2
1.6	Lifting and Unloading Instructions	3
1.6.1	Lift the Scale	3
2.0	Installation	4
2.1	Package Removal	4
2.2	Permanent Installation	4
2.2.1	Installation	4
2.3	Load Cell Wiring and Connections	6
3.0	Replacement Parts	8
3.1	MAS-LC Replacement Parts	8
3.2	MAS-LC – End Gates Replacement Parts	10
3.3	Conduit Replacement Parts	12
3.4	Junction Box (PN 193248) Replacement Parts	13
4.0	Maintenance	14
4.1	Maintenance Schedule	14
4.2	Scale Maintenance Procedures	14
4.3	Replace Flooring	14
4.4	Replace/Clean Load Cell	14
4.4.1	Overload Bolts	15
4.4.2	Load Cells	16
4.5	Troubleshooting	17
4.6	Specifications	18



Technical training seminars are available through Rice Lake Weighing Systems. Course descriptions and dates can be viewed at www.ricelake.com/training or obtained by calling 715-234-9171 and asking for the training department.



Rice Lake continually offers web-based video training on a growing selection of product-related topics at no cost. Visit www.ricelake.com/webinars

1.0 Introduction

The MAS-LC provides reliable, accurate weighing for ranchers and processors that prefer a load cell based weighing system. This scale combines the accuracy of fully electronic weighing technology with steel I-beam weigh bridge designs typically found in heavy capacity vehicle weighing scales.



Manuals and additional resources are available from the Rice Lake Weighing Systems website at www.ricelake.com

Warranty information can be found on the website at www.ricelake.com/warranties

1.1 Safety

Safety Signal Definitions:



DANGER Indicates an imminently hazardous situation that, if not avoided, will result in death or serious injury. Includes hazards that are exposed when guards are removed.



WARNING Indicates a potentially hazardous situation that, if not avoided, could result in serious injury or death. Includes hazards that are exposed when guards are removed.



CAUTION Indicates a potentially hazardous situation that, if not avoided, could result in minor or moderate injury.



IMPORTANT Indicates information about procedures that, if not observed, could result in damage to equipment or corruption to and loss of data.

General Safety



Do not operate or work on this equipment unless this manual has been read and all instructions are understood. Failure to follow the instructions or heed the warnings could result in injury or death. Contact any Rice Lake Weighing Systems dealer for replacement manuals.



Failure to heed could result in serious injury or death.

Do not allow minors (children) or inexperienced persons to operate this unit.

Do not operate without all shields and guards in place.

Do not use for purposes other than weighing.

Do not place fingers into slots or possible pinch points.

Do not place hands, feet or body part underneath the scale at any time. Scale could be lowered at any time, crushing body parts.

Do not use any load bearing component that is worn beyond 5% of the original dimension.

Do not use this product if any of the components are cracked.

Do not exceed the rated load limit of the unit.

Do not make alterations or modifications to the unit.

Do not remove or obscure warning labels.

Keep hands, feet and loose clothing away from moving parts.

Be sure the gates are latched or tied inward before transporting the scale.

1.2 Animal Safety

Animal safety is a very serious issue and must be observed when handling any type of animal.

The scale surface may become slippery during use; a build-up of manure on the scale may reduce traction. It is recommended to take any necessary precautions to maintain an acceptable level of animal footing.

1.3 Calibration

Do not calibrate this scale with a weight cart having a gross weight in excess of 25% of the total capacity of the scale.

This device is designed to be calibrated with single block weights spread evenly throughout the floor of the scale. If using a test cart, use 3/4" plywood for testing and calibration. This will minimize the damage to the X-lug floor. Shift tests should not be done with more than 4,000 lb or 1,815 kg in a 4' x 4' area. Failure to comply with this warning will result in damage to the scale and void the warranty.

1.4 Safety Decals

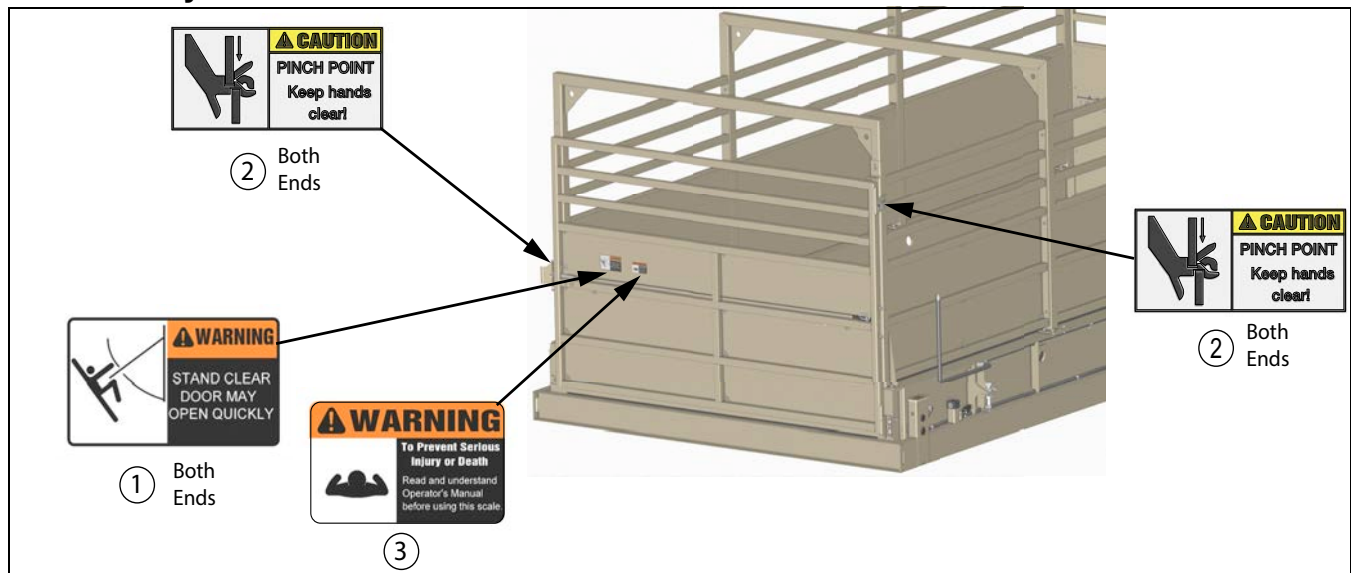

Figure 1-1. Safety Decals

Item No.	Part No.	Description	Qty.
1	151902	Warning, Opens Quickly	2
2	151909	Caution, Pinch Point	6
3	151908	Read Manual	1

Table 1-1. Safety Decals Parts List

1.5 Overview

The MAS-LC animal scale consists of a sheeted animal cage suspended by four S-type load cells on top of a stationary base frame. When transporting, the scale system is locked down using overload bolts, protecting the load cells from damage during transport. A digital indicator can be connected to the scale to display the weight.

The MAS-LC animal scale can be used on any firm surface that is straight, plumb and level.



Legal for Trade applications often require a concrete slab foundation. Check with local Weights and Measure officials in the area.

1.6 Lifting and Unloading Instructions

Lift the scale using the lift brackets, supplied lifting bands, four lifting straps or chains with safety latch hooks and a crane or loader. Ensure the overload stop bolts are in the transport mode (locked down – see [Section 1.6.1](#)) when loading and transporting the scale.



Note *Lifting bands are required on all units less than 10' wide.*

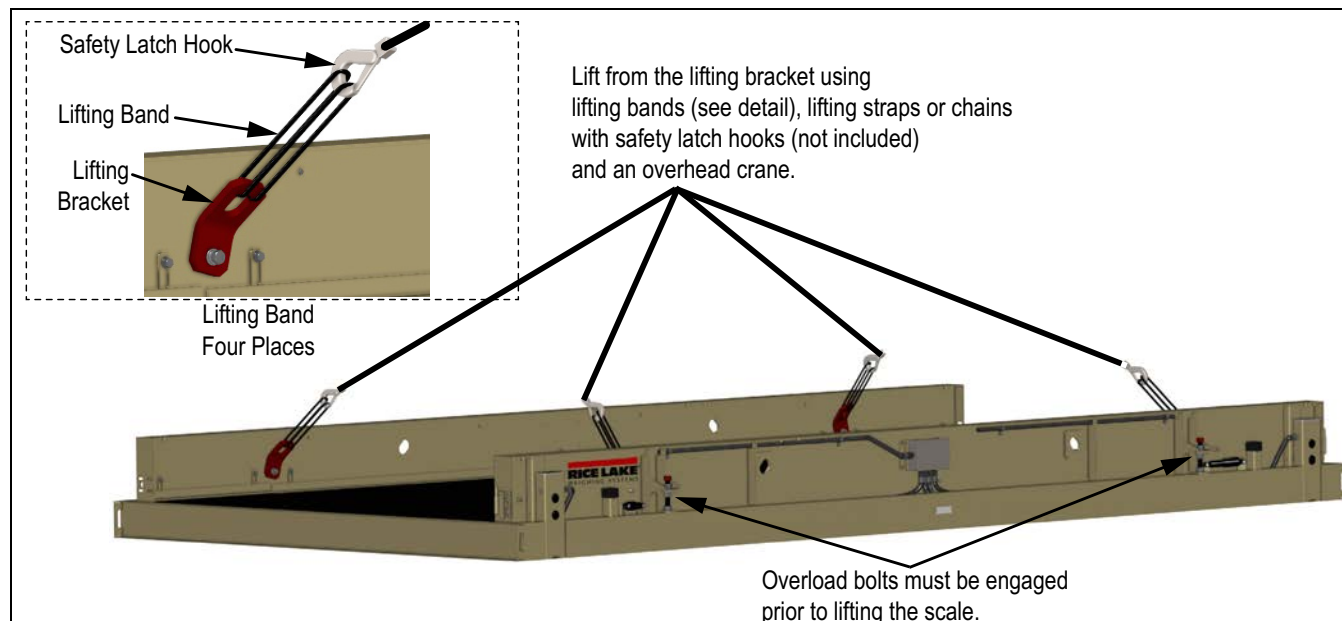

Figure 1-2. Lift Points

1.6.1 Lift the Scale

1. Lift the scale using adequate lifting straps and device.
2. Place on a prepared location – a firm surface that is straight, plumb and level. Store scale on the same type of surface.



The unit is very heavy. Ensure that adequate straps are used for lifting the scale and that straps are in the proper location. See [Table 1-2](#) for strap lengths.

Ensure no one is under the scale when lifting and moving into the location selected.



Lifting bands on the lift brackets are to be used only for unloading the scale from the truck. Ensure the lifting device safety latch hooks are securely through both end of the bands before attempting to lift. Once the scale is in place, the bands must be removed from the lift brackets and discarded.

Model	Minimum Strap Length
13' x 8'	8'
15' x 8'	9'
17' x 8'	9.5'
19' x 8'	10.5'
22' x 8'	12'
22' x 10'	13'

Table 1-2. Minimum Strap Length for Lifting

2.0 Installation

This section provides an overview of Stationary Livestock Scale – MAS-LC installation information.

2.1 Package Removal

The indicator is shrink wrapped for transportation. Be careful when removing to avoid damaging the scale. Place the parts in a safe location so they will not be damaged.

2.2 Permanent Installation

Assembly of the MAS-LC at its permanent location is recommended. As with any weighing equipment, the accuracy of the scale is dependent on the installation. In all installations, the scale must be level to ensure proper operation.

A concrete foundation (piles or piers) for permanent installations is recommended. The foundation must be able to support the gross weight of the scale (dead weight plus capacity), and the piles or piers must be situated directly under the load cell stands. The foundation must not be subject to distortion or motion due to frost action. A qualified local professional should be consulted to recommend the proper size of foundation for the location. Foundation dimensional requirements are available from the dealer or Rice Lake Weighing Systems. Requirements may vary from one Weights and Measures jurisdiction to another, please contact the local office.

2.2.1 Installation



Note Concrete drawings are available upon request.

IMPORTANT

Retain overload bolts and nuts to use during load cell replacement and/or future relocation of the scale.

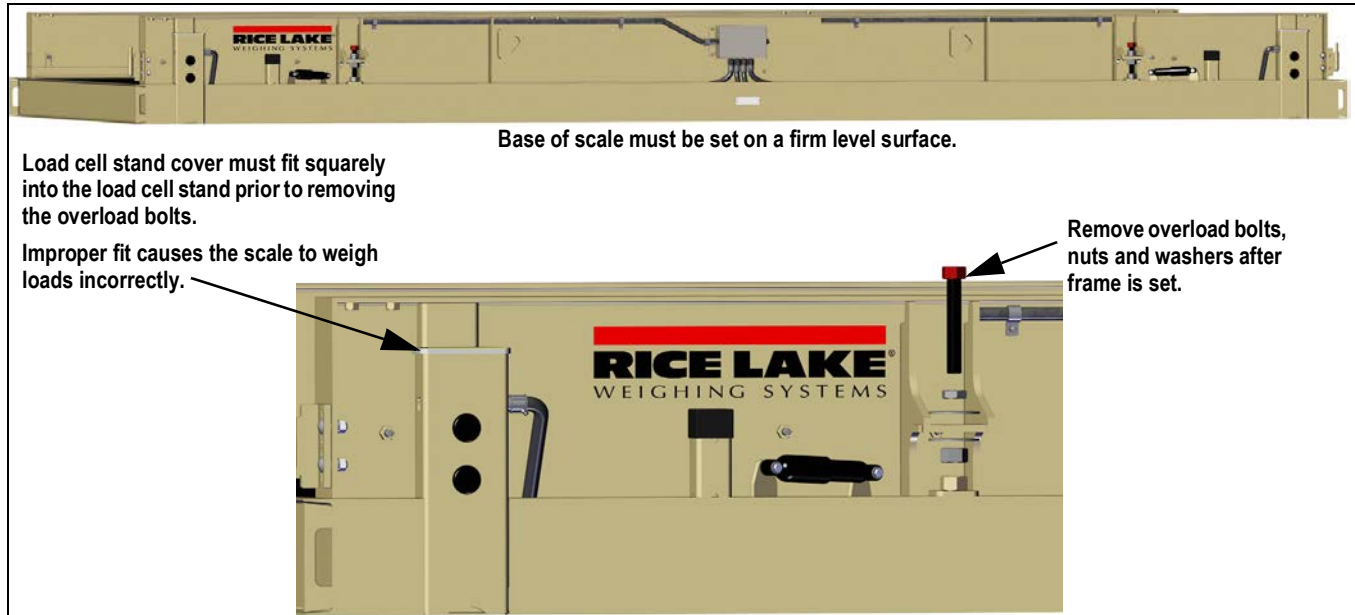

Figure 2-1. Scale Base Frame and Overload Bolts

1. Place base frame on a firm surface that is straight, plumb and level.
2. Remove overload bolts.

IMPORTANT

Do not tighten hardware at this time, it needs to be loose to allow for wall panel installation.



CAUTION

Upright and wall installation should be done with two people or an overhead crane to avoid personal injury.

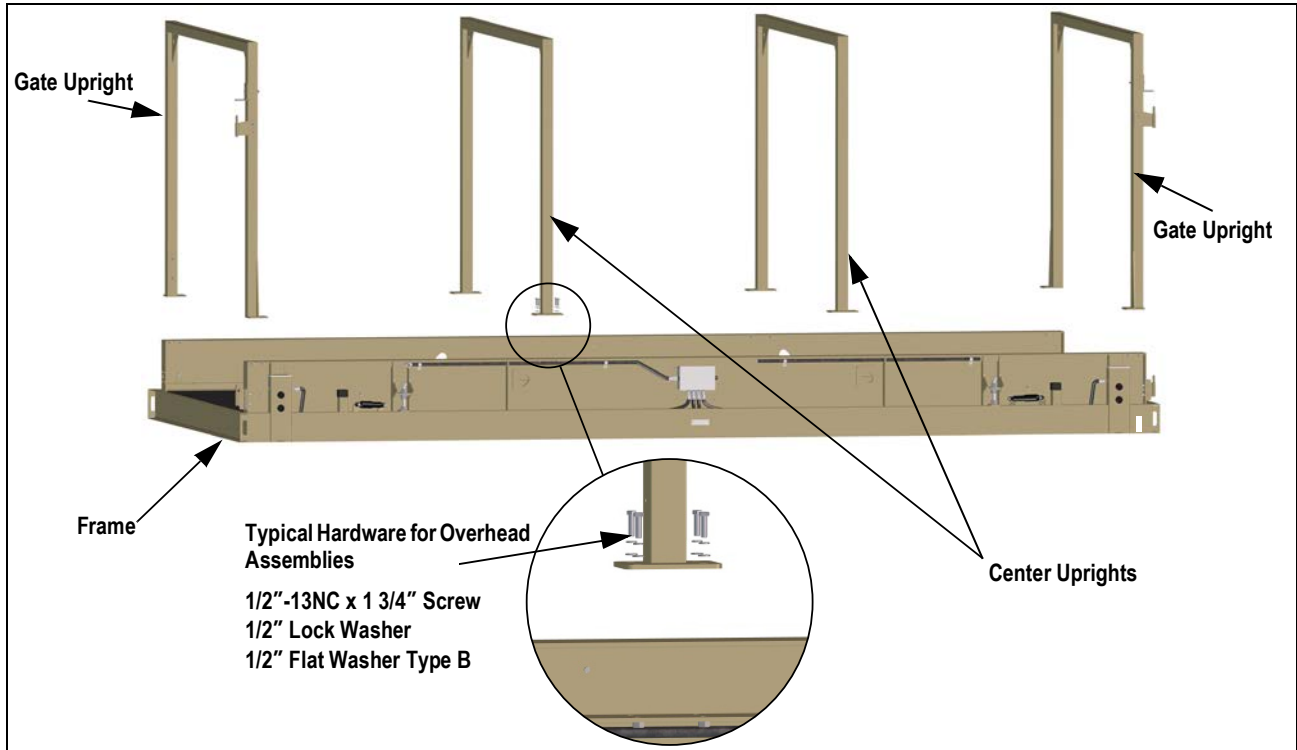

Figure 2-2. Install Internal Overhead Assemblies

3. Install the two internal upright assemblies and the two gate upright assemblies to the base frame using the hardware provided.

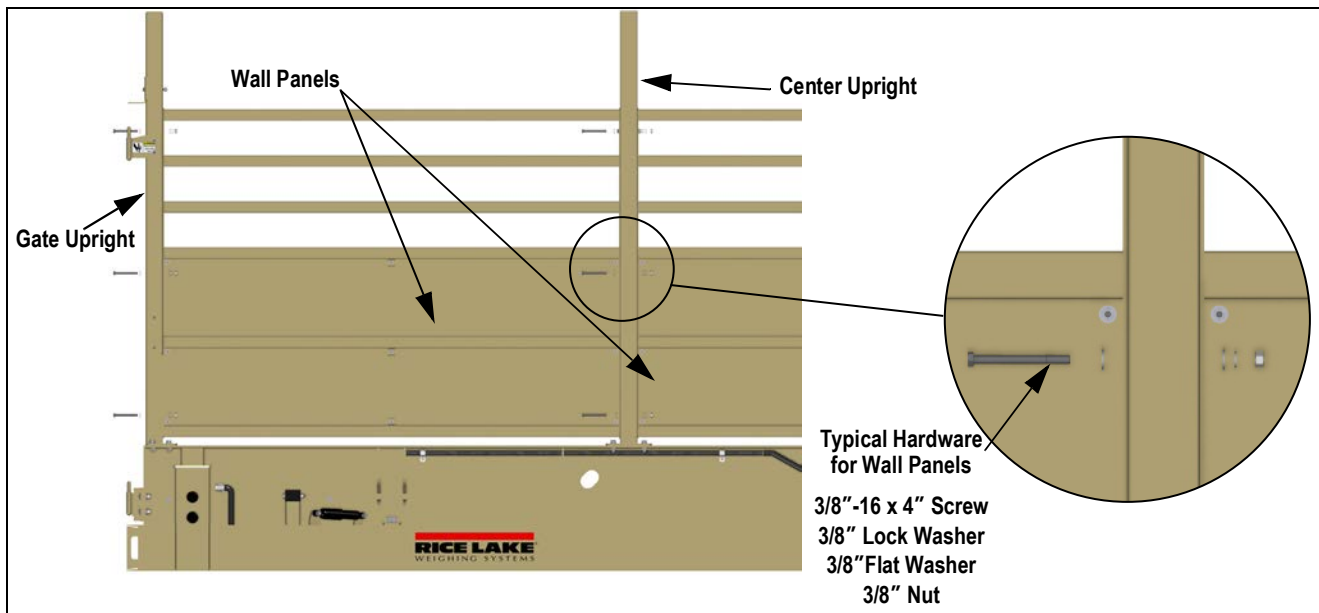

Figure 2-3. Install Wall Panels

4. Align holes in wall panels with holes in uprights and secure in place with provided hardware.
5. Tighten hardware for the wall panels then tighten hardware securing the uprights to the frame.

IMPORTANT

At center uprights, hardware goes through two wall panels (one on each side of the upright).

- Align top hinge section on gate with lower hinge section on upright and lower gate onto the bottom hinge section.

IMPORTANT

The latch should line up with the strike plate welded to the end upright. If it does not align, washers are supplied to adjust the gate. Remove gate from hinges and place washers on the upright hinge, then reinstall the gate. Use washers as to align the latch to the striker plate.

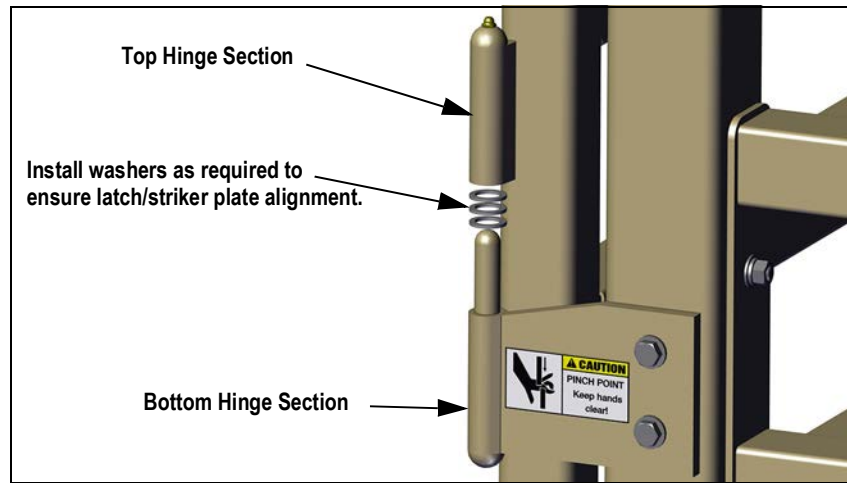

Figure 2-4. Gate Installation and Alignment

2.3 Load Cell Wiring and Connections

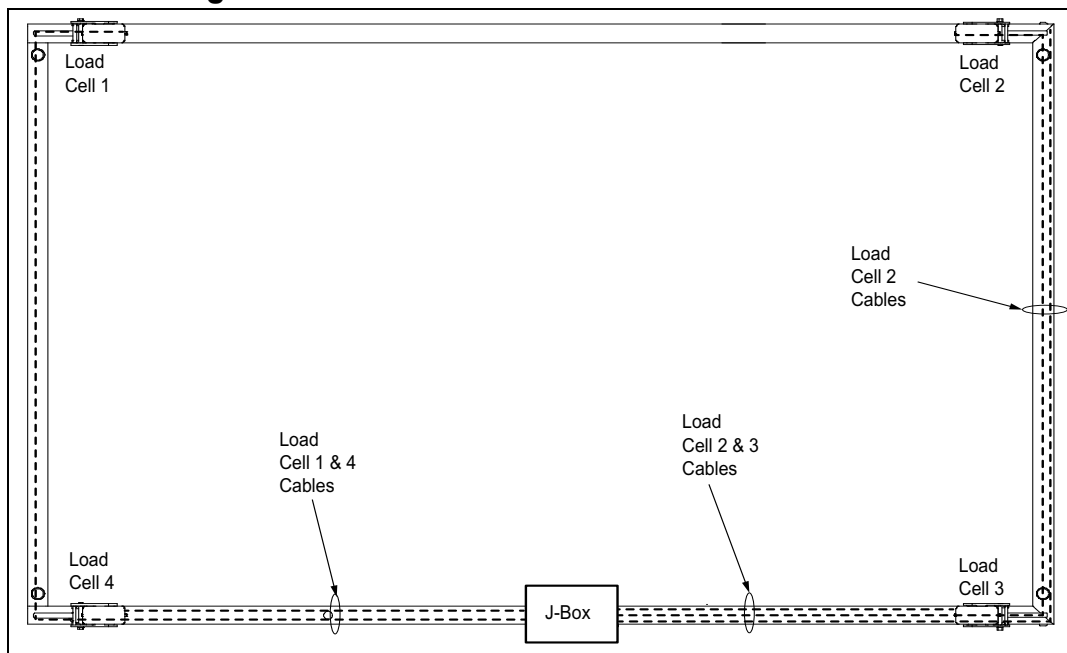

Figure 2-5. Junction Box Wiring Connection



Note Load cell wiring shown is effective for all models after 09/17/2013. Models built prior to that date should be wired to the updated configuration. For information on rewiring the scale, download Technical Bulletin (PN 159193) at www.ricelake.com.

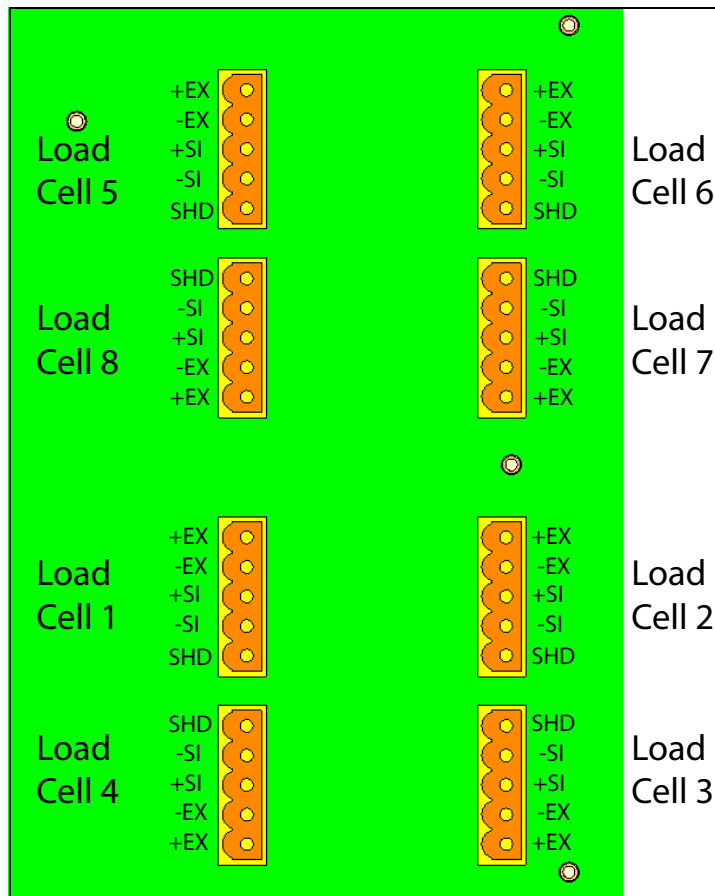

Figure 2-6. Load Cell Wiring Diagram

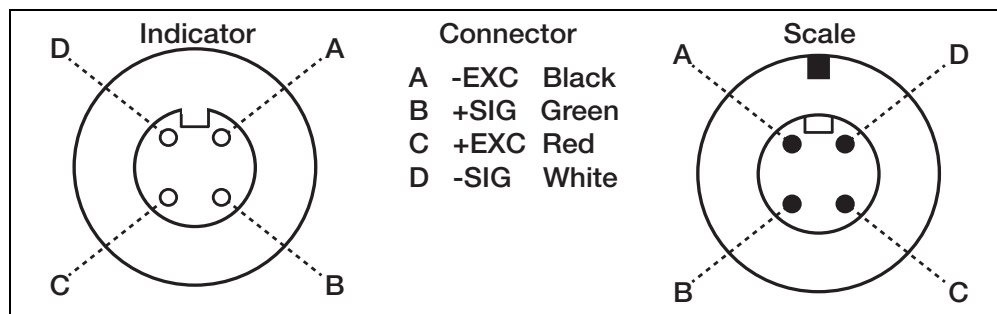

Figure 2-7. Indicator/Scale System Connections

Conn PN	Description	Used With	Cap PN	Cap Description
127259	Conn, MS Male Complete Kit	127260 or 127261	15731	Dust Plug, MS External THD
127260	Conn, MS Female Pin w/ Clamp	127259	15730	Dust Cap, MS INTL THD

Table 2-1. Weighcenter Connector and Plug Configurations

3.0 Replacement Parts

This section provides an overview of Stationary Livestock Scale – MAS-LC replacement parts information.

3.1 MAS-LC Replacement Parts



Replacement parts shown in [Figure 3-1](#) and [Table 3-1](#) on page 9 are for MAS-LC models built in 2019 and newer. For older MAS-LC model replacement parts contact Rice Lake Weighing Systems at www.ricelake.com.

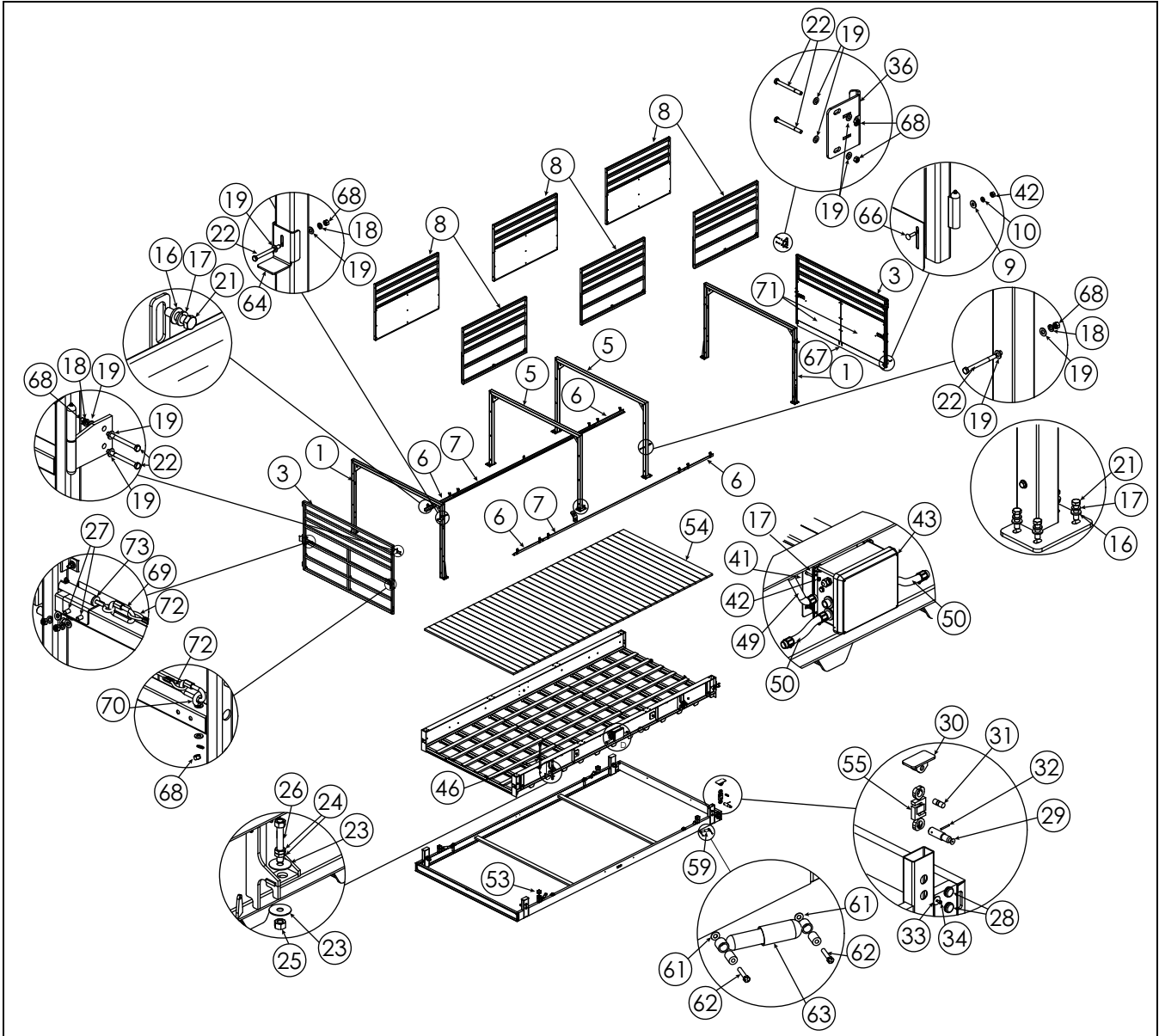

Figure 3-1. MAS-LC Parts Illustration

Item No.	Part No.	Description	Item No.	Part No.	Description
1	185923	End overhead, 7'	42	14641	Nut, 1/4-20NC Hex Zinc
	192423	End Overhead, 10'	43	193248	Junction Box
3	185926	Gate Assembly, 7'	44	159337	Bolt, 1/4-20NF x 1-1/2 Hex Full Thread, SST
	192424	Gate Assembly, 10'	NS	158143	Homerun Cable
5	151169	Internal Overhead, 7'		127261	Connector
	154678	Internal Overhead, 10'		15730	Dust Cap
6	186028	Angle, Flooring Hold Down, 36"	46	188761	Conduit Assembly, 40"
7	192084	Angle, Flooring Hold Down, 13'	47	188762	Conduit Assembly, 24"
	191911	Angle, Flooring Hold Down, 15'	NS	188763	Conduit Assembly, 24", Rigid to Flex
	191568	Angle, Flooring Hold Down, 17'	49	188764	Conduit Assembly, 19-1/2"
	186029	Angle, Flooring Hold Down, 19'	50	188765	Conduit Assembly, 10"
	192129	Angle, Flooring Hold Down, 22'	51	188766	Conduit Assembly, 16"
8	151174	Wall Segment 18x7 (13'-qty 4 / 19'-qty 6)	53	173125	Boot for Pedestal Tube
	151176	Panel, 18 x 7 (for PN 151174)	54	191820	22' x 10' X-Lug Package
	154095	Wall Segment (15'-qty 4 / 22'-qty 6)		191821	22' x 10' X-Plank Package
	154097	Panel, 20 x 7 (for PN 154095)		191822	22' x 8' X-Lug Package
	155821	Wall Segment (17'-qty 4)		191823	22' x 8' X-Plank Package
	155823	Panel, 17 x 8 (for PN 155821)		191824	19' x 8' X-Lug Package
9	191611	Hinge, Universal Upper		191825	19' x 8' X-Plank Package
10	15147	Washer, Lock 1/4" Regular		191826	17' x 8' X-Lug Package
11	14641	Nut, Hex 1/4-20 NC		191827	17' x 8' X-Plank Package
12	192626	Hinge, Universal Lower		191828	15' x 8' X-Lug Package
13	163215	Hinge Bushing		191829	15' x 8' X-Plank Package
14	174712	Bolt, Carriage 1/2-13NC		191830	13' x 8' X-Lug Package
15	14674	Nut, 1/2-13NC Hex Steel		191831	13' x 8' X-Plank Package
16	15173	Washer, Plain 1/2" Type B		55	127673
17	15167	Washer, Lock 1/2" Regular	167452		Load Cell Assembly, OBW 10K Low Profile with Eyebolts Installed 40' Cable
18	15159	Washer, Lock 3/8" Regular Zinc	59	163212	Shock Assembly, MAS-LC
19	21938	Washer, Plain 3/8" Type A	61	15161	Washer, Plain STD 3/8" SST
21	121483	Bolt, Cap 1/2-13NC x 1-3/4"	62	22093	Screw, Cap 3/8-16NC x 2" Hex
22	127003	Screw, Cap Hex 3/8-4" Grade 5 Zinc	63	128626	Damper Assembly
23	159935	Washer, Plain 1" ID x 3-1/2" OD	NS	131374	Paint, Gray Beige Aerosol
24	14701	Jam Nut Hex, 1-8NC Zinc	64	164363	Bracket, Lift Stop
25	45852	Nut, 1-8NC Heavy Hex	66	132917	Carriage Bolt, 1/4-20 NC Hex Steel
26	F1682RR	Bolt, 1-8UNC x 6-3/4", Full Thread	67	159783	Kick Panel, 7'
27	127013	Screw, Cap Hex 3/8-16 x 3" Grade 5 Zinc		164153	Kick Panel, 10'
28	126789	Plug, Plastic for Round 2"	68	132684	Nut, Hex 3/8-16NC Grade 5 Zinc
29	153941	Mount, Lower Load Cell Pin	69	150715	Quick Link, 3/8"
30	153943	Mount, Upper Load Cell Pin	70	150820	Eyebolt, 3/8-16NC x 3"
31	153940	Upper Cell Pin	71	159783	Panel, Gate 7'
32	171983	Pin, 1/4" x 2-1/4" Slotted		164153	Panel, Gate 10'
33	174640	Retainer, Lower Load Cell Pin	72	150716	Cable, Latch 1/4" OD, 7'
34	118020	Screw, Cap 5/16-18NC x 5/8"		154690	Cable, Latch 1/4" OD, 9'
35	45727	Strap, Conduit 3/4" Zinc	73	141394	Gate Latch Assembly
36	186458	Strike Plate Assembly		131702	Gate Latch Spring
37	111075	Bolt, 1/4-20NC x 1 Hex Grade 2 Galv		160302	Hairpin, 08 x 1-9/16"
40	127007	Screw, Cap 1/4-20 x 1/2"			
41	185902	Mount Bracket, Junction Box			

Table 3-1. MAS-LC Parts List

3.2 MAS-LC – End Gates Replacement Parts

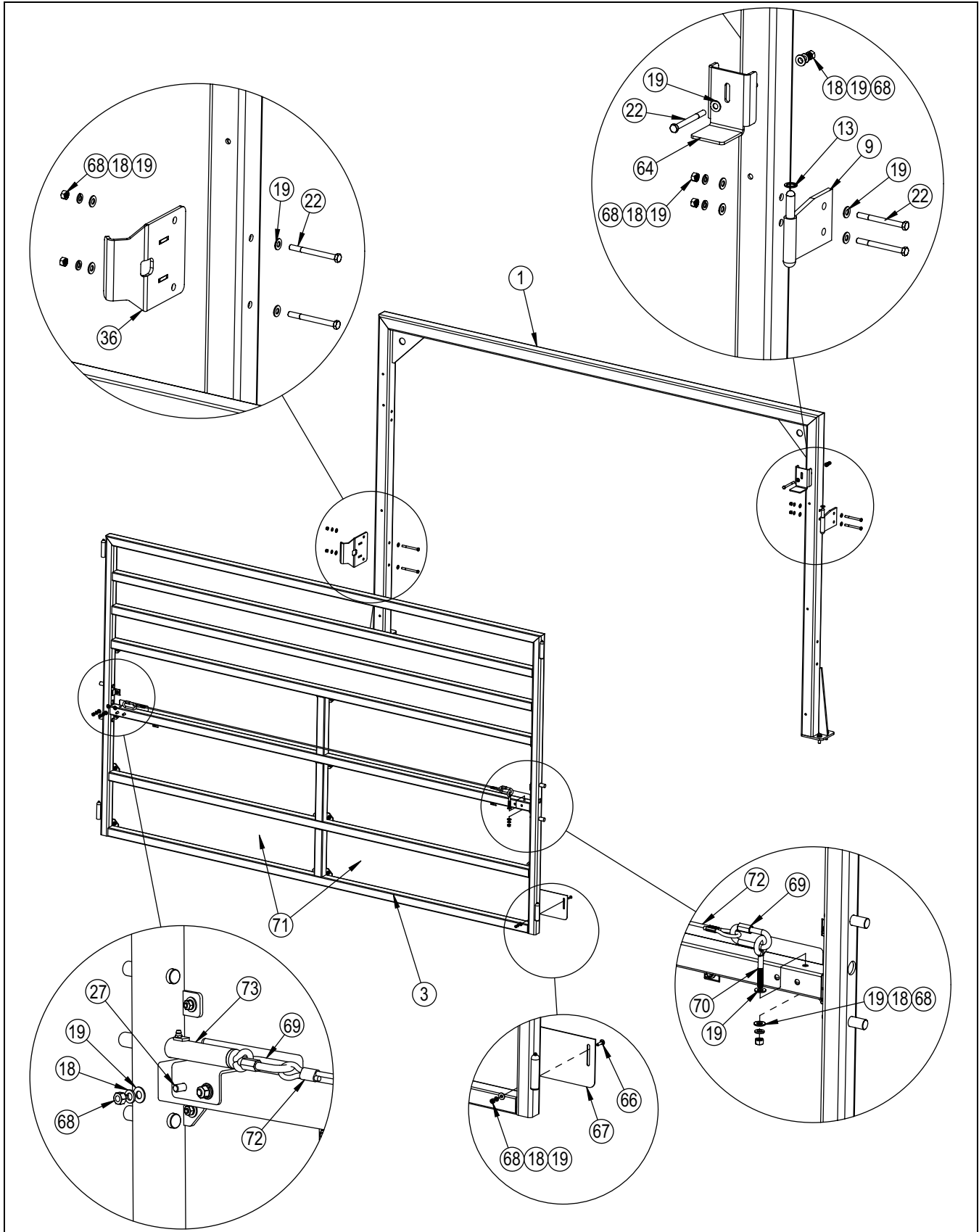

Figure 3-2. MAS-LC – End Gates Parts Illustration

Item No.	Part No.	Description
1	185923	End Overhead, 7'
	192423	End Overhead, 10'
3	185926	Gate Assembly, 7'
	192424	Gate Assembly, 10'
9	191611	Hinge, Universal Upper
13	163215	Hinge Bushing
18	15159	Washer, Lock 3/8" Regular Zinc
19	21938	Washer, Plain 3/8" Type A
22	127003	Screw, Cap Hex 3/8-4" Grade 5 Zinc
27	127013	Screw, Cap Hex 3/8-16" x 3" Grade 5 Zinc
36	186458	Strike Plate Assembly
64	164363	Bracket, Lift Stop
66	14731	Carriage Bolt, 1/4-20" NC Hex Steel (qty 4)
67	159783	Kick Panel, 7'
	164153	Kick Panel, 10'
68	132684	Nut, Hex 3/8-16" NC Grade 5 Zinc
69	150715	Quick Link, 3/8"
70	150820	Eye Bolt, 3/8-16" NC x 3"
71	159783	Panel, Gate 7'
	164153	Panel, Gate 10'
72	150716	Cable, Latch 1/4" OD, 7'
	154690	Cable, Latch 1/4" OD, 9'
73	141394	Gate Latch Assembly
	131702	Gate Latch Spring
	160302	Hairpin, 0.08 x 1 9/16"

Table 3-2. MAS-LC Gates Parts List

3.3 Conduit Replacement Parts

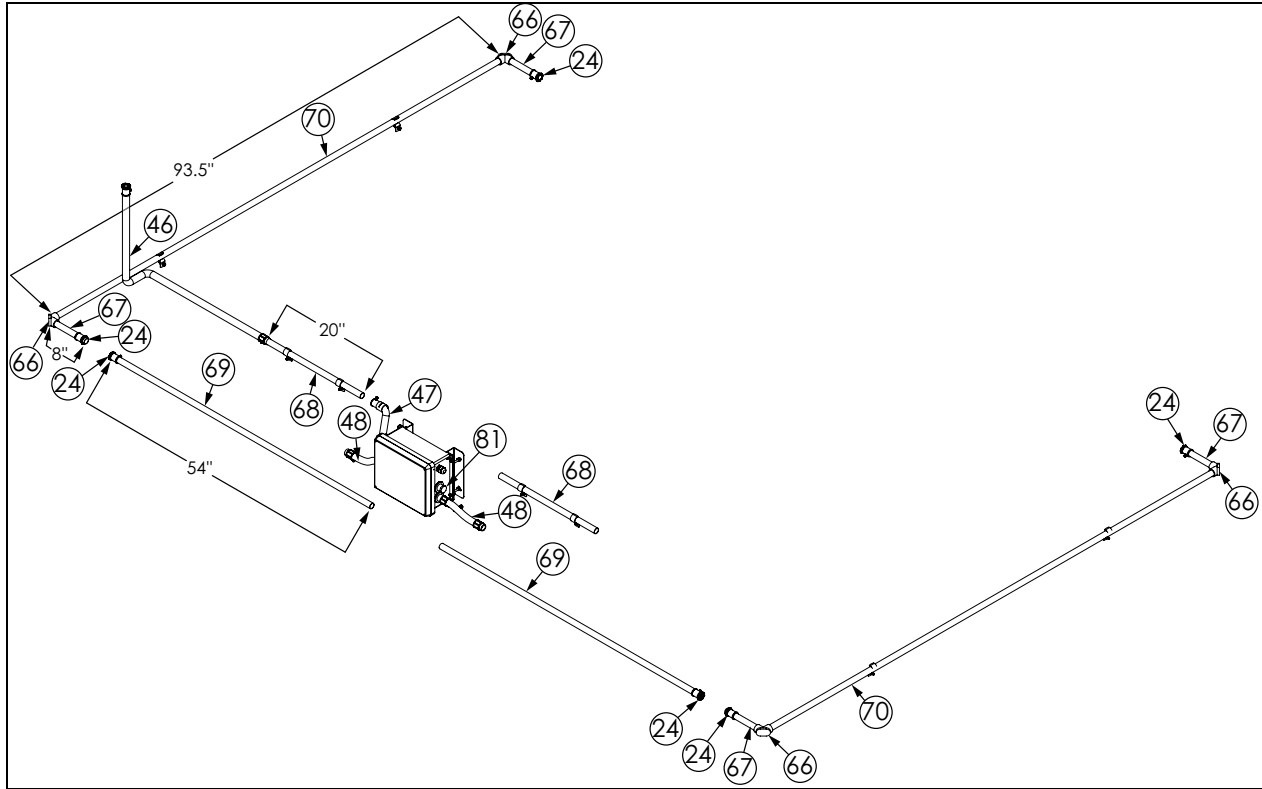

Figure 3-3. Conduit Parts Illustration

Item No.	Part No.	Description	Qty.
24	45339	Conduit Connector, 3/4"	7
46	188761	Conduit Assembly, 180° x 90° 40" Long	1
47	188764	Conduit Assembly, 180° x 180° 19.5" Long	1
48	188765	Conduit Assembly, 180° x 180° x 13.5" Long	2
66	65357	Elbow, 90° Pull	4
67	45572-7	Conduit, Electrical 3/4	4
68	45572-20	Conduit, Rigid, 3/4 x 20" Long Galvanized Steel	2
69	45572-54	Conduit, Rigid, 3/4 x 70" Long Galvanized Steel	2
70	45572-93	Conduit, EMT, Rigid, 3/4 ID x 93.5" Long	2
81	193925	Plug, 3/4" PVC, Schedule 40, Hex Head, 3/4" M-NPT	1

Table 3-3. Conduit Parts List

*Only usable on 10' wide models

Scale	Conduit Balloon Numbers and Corresponding Lengths			
	71	72	73	74
13' x 8'	7"	93.5"***	20"	54"
15' x 8'	7"	93.5"***	20"	70"
17' x 8'	7"	93.5"***	42"	80"
19' x 8'	7"	93.5"***	42"	93.5"
22' x 8'	7"	62"*	62"	102"
22' x 10'	7"	61"*	62"	102"

Table 3-4. Conduit Lengths

*10' requires two per width

**8' requires one per width

3.4 Junction Box (PN 193248) Replacement Parts

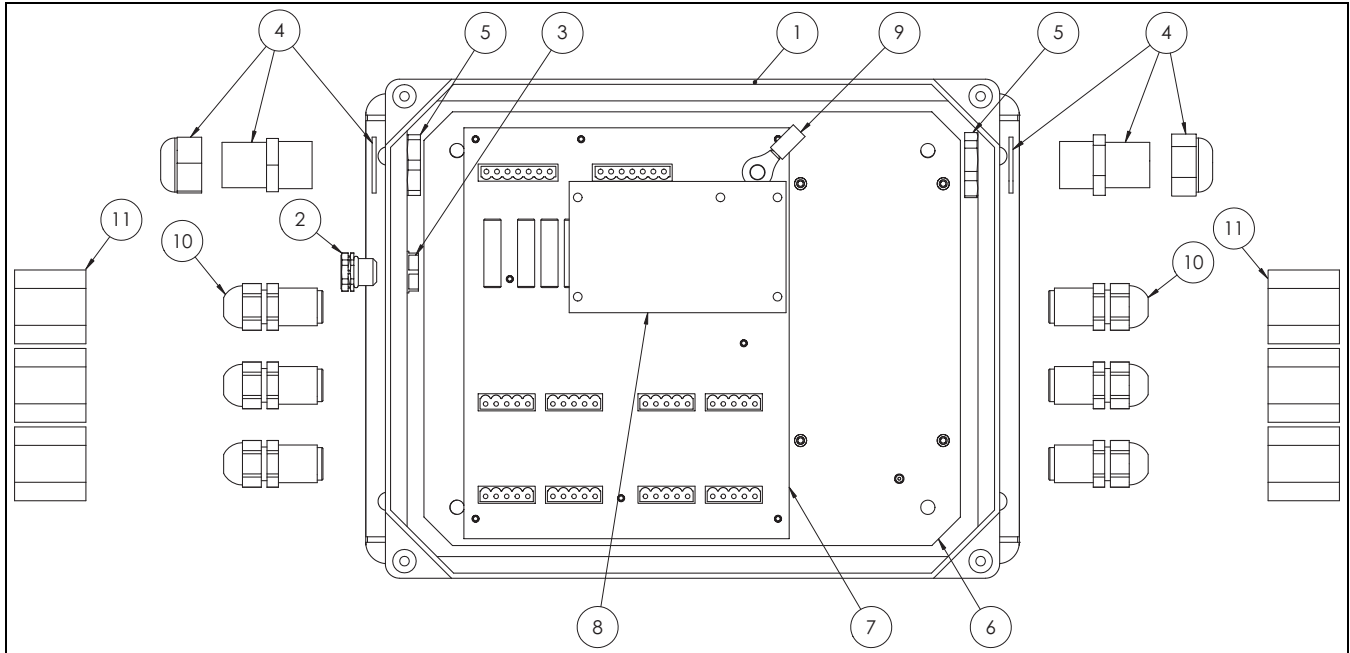

Figure 3-4. Junction Box Parts Illustration

Item No.	Part No.	Description	Qty.
1	193246	Enclosure, Machined FRP Junction Box Truck Scale 10x8x6 with 4 Screws	1
2	88733	Vent, Breather Sealed Gortex Membrane Black Plastic	1
3	88734	Nut, Breather Vent M12x1 Thread	1
4	15628	Cord Grip, 1/2 NPT Black Clamping Range = 197 - 472	2
5	15630	Lock Nut, 1/2-NPT Plastic	2
6	91896	Component Plate, Junction Box JB8SP, JB8ST Large, Used in Truck Scale Weldments	1
7	89889	Board, 8 Channel ST Signal Trim And Section Trim with Expansion	1
8	89894	Board Assembly, Transient GDT Summing Box Transient Protection Board	1
9	43810	Conn, Ring Terminal 1/4" 10-12 AWG	1
10	15655	Cord Grip 3/8 NPT	6
11	92735	Assembly, Coupling & Cap bonded, 3/8" NPT Cap to Coupling 92575	6

Table 3-5. Junction Box Parts List

4.0 Maintenance

This section provides an overview of Stationary Livestock Scale – MAS-LC maintenance information.

4.1 Maintenance Schedule

Weekly

1. Check entire scale for buildup of debris. Remove any debris found on, under or around the scale.
2. Check for dirt and debris in the load cell stands and clean accordingly.
3. Check all external cables and conduit for damage.

Monthly

Grease hinges and latch assembly.

4.2 Scale Maintenance Procedures

Cleaning Load Cell Stands

It is very important to keep any excess debris from building up in the load cell stand. Lift scale, block it up, and clean any dirt out of the load cell stands through the drain holes located at the bottom of the stand.

4.3 Replace Flooring

1. Remove the hold down angle on both side of the floor by loosening the bolts.
2. Remove section(s) of flooring that are to be replaced.
3. Install new flooring.
4. Reinstall the hold down angles.

4.4 Replace/Clean Load Cell

To ensure the long life of the unit, perform the following instructions for cleaning or replacing the load cells. See [Figure 2-6 on page 7](#) for the parts list drawings for item numbers.

IMPORTANT *Avoid bending or twisting the load cell wires.*

4.4.1 Overload Bolts

Prior to replacing or cleaning the load cells, the overload bolts must be installed to release tension on load cells.

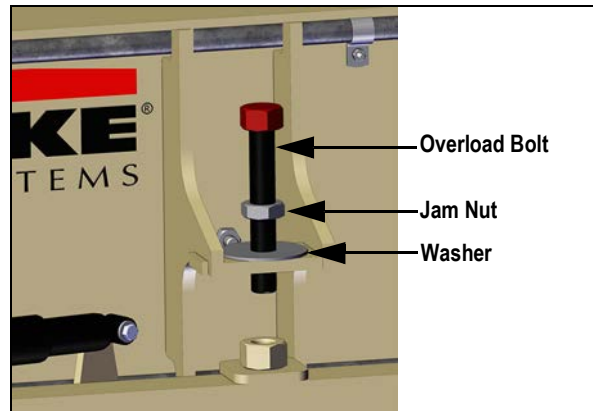

Figure 4-1. Overload Bolt

1. Install the jam nut on the overload bolt.
2. Align one of the washers with the hole in the overload bracket
3. Insert the bolt assembly through the washer and the bracket.



Figure 4-2. Insert Overload Bolt

4. Place a second washer on the bottom of the bolt and install a nut on the bolt to secure the assembly to the bracket.
5. Adjust the jam nut and bottom nut until the bolt can be tightened into the nut until it touches the frame.

IMPORTANT

Bolt must touch the frame for it to work properly. Adjust the jam nut to float during shipping.



Note *Save the overload components for use with future cleanings.*

4.4.2 Load Cells

Once the overload bolts are in place, the load cell can be removed.

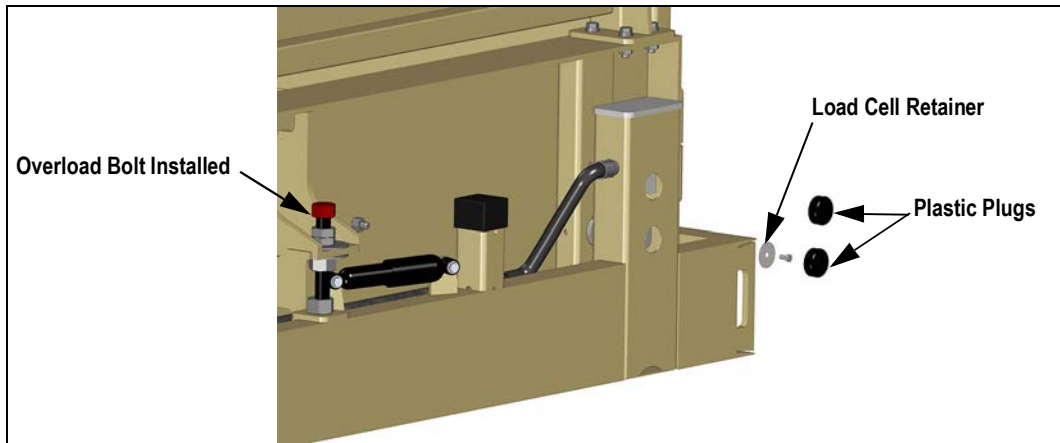

Figure 4-3. Plastic Plugs

6. Remove the plastic plugs.
7. Remove the load cell retainer.

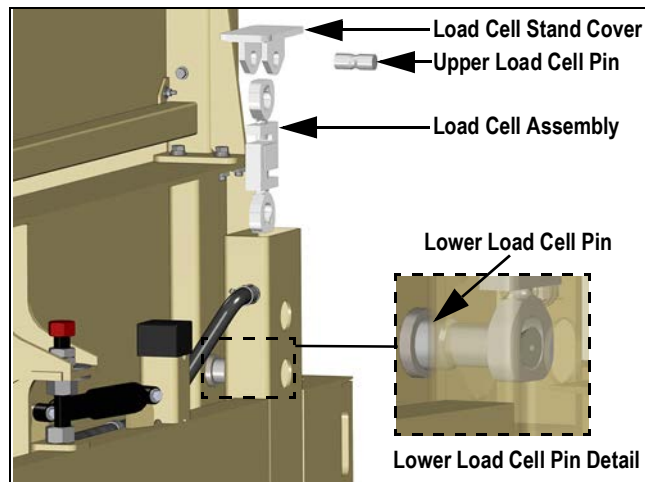

Figure 4-4. Load Cell Removal

8. Pull load cell away from the lower load cell pin and pull load cell stand cover with the load cell assembly up and out of the load cell stand.
9. Remove the upper load cell pin to release the load cell from the load cell stand cover.
10. Reverse the steps above to reinstall load cell.

IMPORTANT

Load cell stand cover must fit squarely into the load cell stand before removing the overload bolt assemblies (Section 2.2.1 on page 4).

4.5 Troubleshooting

Symptom	Probable Cause	Action
The weight reading on the indicator is unstable	The circuit board in the control panel may be wet or the junction box for the load cells may have moisture	Dry any areas that are contaminated with moisture; Check for leaks and reseal
	A load cell cable may be pinched or damaged	Contact RLWS or a qualified dealer for support; Cutting the load cell cable will void the warranty; Special repair techniques are required
The scale has a positive error when loading or a negative error when unloading	Mechanical binding problem on scale	Check for debris around or under the scale; Check each load cell location for foreign material; Check all items that run from on the scale to off the scale; Check all gates or gathering panels for contact;
The scale has a negative error when loading or a positive error when unloading	Moisture is present somewhere in the electrical system	Dry any areas that are contaminated with moisture; Check for leaks and reseal
Scale will not ZERO	Weight on scale larger than the allowable ZERO window	Clean the scale deck of debris, then zero the scale
	–	ZERO window parameter set incorrectly
System does not operate-no display	Power disconnected	Check and reconnect
	Indicator fuse blown	Replace fuse; Check for cause
	Interface cable cut or disconnected	Repair
	Signal leads incorrectly installed at indicator	Install according to indicator installation manual
Display stays at ZERO	Indicator faulty	Service indicator
	Load cell connections faulty	Check cable connections in junction box and at indicator
Erratic weights	Vibration near scale	Remove source of vibration (or remove scale)
	Platform not level within 1/4"	Level scale by adjusting feet or shimming if necessary
	Load cell or cable water damage	Replace
	Debris under load cells or platform	Clean
	Indicator faulty	Use simulator to test indicator for stability; Service indicator
Consistently high or low weights	Indicator not properly adjusted to ZERO	ZERO the indicator according to indicator manual
	Platform binding	Obtain adequate clearance for free platform movement
	Indicator not calibrated	Calibrate according to indicator manual
	Feet touching deck underside	Adjust feet downward to provide clearance

Table 4-1. Troubleshooting

IMPORTANT If a problem with the scale is suspected, contact Rice Lake Weighing Systems or a qualified local scale dealer.

The space between the platform side, weigh bridge and frame, and the surface beneath the platform must be periodically cleaned to prevent debris build up. More frequent cleaning of these areas is necessary with scales mounted in pits.

4.6 Specifications



Specification	LMA 13 x 8	LMA 15 x 8	LMA 17 x 8	LMA 19 x 8	LMA 22 x 8	LMA 22 x 10
Overall Length	13'	15'	17'	19'	22'	22'
Deck Length	12' - 1"	14"	16"	18"	20" - 11"	20" - 11"
Overall Width	8'	8'	8'	8'	8'	10'
Deck Width	6' - 6"	6' - 6"	6' - 6"	6' - 6"	6' - 6"	9'
Deck Height	8"	8"	8"	8"	8"	8"
Height	8"	8"	8"	8"	8"	8"
Weight	4900 lb	5450 lb	5420 lb	6040 lb	7300 lb	7900 lb
Capacity	25000 lb	25000 lb	25000 lb	25000 lb	25000 lb	25000 lb
Approval Class	IIIL(IIHHD)	IIIL(IIHHD)	IIIL(IIHHD)	IIIL(IIHHD)	IIIL(IIHHD)	IIIL(IIHHD)
Approvals	 99-091  AM4847					
Grad Size	5 lb (2 kg)	5 lb (2 kg)	5 lb (2 kg)	5 lb (2 kg)	5 lb (2 kg)	5 lb (2 kg)
Paint	Powder Coated Steel					

Table 4-2. Specifications

Notes

Size / Model # _____
 Serial # _____
 Date Purchased _____
 Unit ID # _____



© Rice Lake Weighing Systems Specifications subject to change without notice.
Rice Lake Weighing Systems is an ISO 9001 registered company.

230 W. Coleman St. • Rice Lake, WI 54868 • USA
U.S. 800-472-6703 • Canada/Mexico 800-321-6703 • International 715-234-9171 • Europe +31 (0)26 472 1319