

MSI DYNA-CLAMP

Tension Meter



RICE LAKE[®]
WEIGHING SYSTEMS

800-472-6703
www.ricelake.com

MSI DYNA-CLAMP

TENSION METER



Quickly Check Wire Rope Tension

The MSI Dyna-Clamp tension meter has a wire rope engagement site window to help ensure accurate tension readings. The MSI Dyna-Clamp features an easy-turn power screw, to make measuring wire rope tension simple and effortless, even in difficult environments.

Meeting Safety Standards with Every Application

The MSI Dyna-Clamp has accommodations for a safety strap, complying with OSHA requirements. Users can measure wire ropes with up to one-inch diameters without changing equipment.

Large, Easy-To-Read Display

The Dyna-Clamp's large LCD display can be clearly read in bright, sunny conditions and features a scratch-resistant overlay for added durability. Two lines on the display allow users to view two measurements. The live wire rope tension is prominently displayed on the primary display line, while the secondary display line is configurable to show wire rope diameter, average tension, or peak tension.

APPLICATIONS

- Tower and stack guy wires
- Pretensioned cable barriers
- Bridges
- Elevators
- Winch ropes
- Overhead electric transit wires
- Fall arrest systems
- Aircraft cables and utilities
- Zip lines

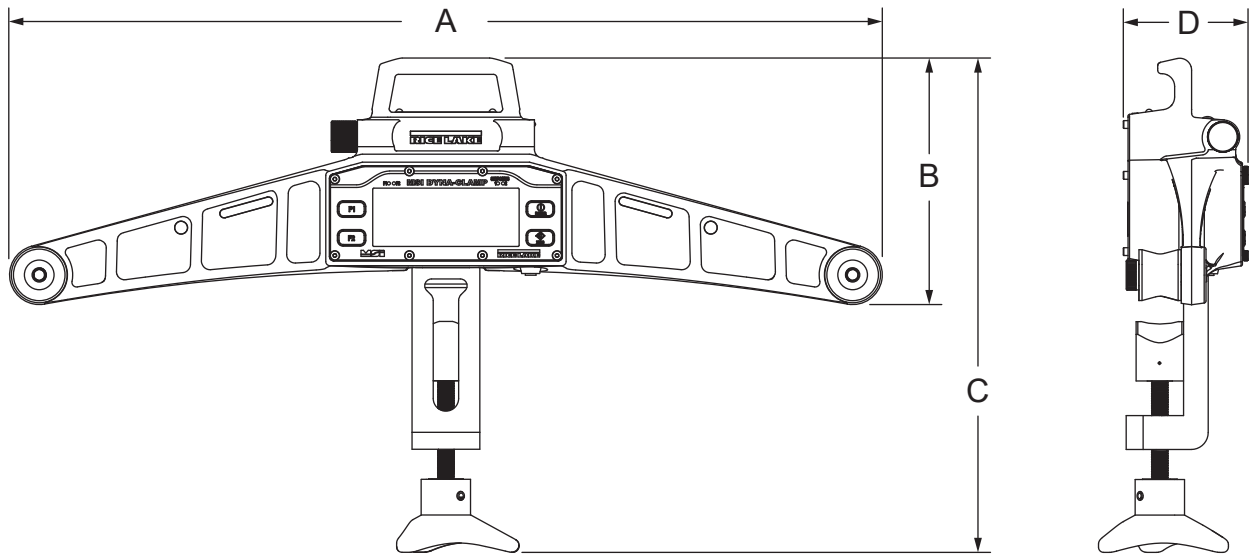

SPECIFICATIONS

POWER:	Battery Operated Two AA Cell 1.5 V Alkaline Batteries (can be replaced with rechargeable NiMH cells)
MAX TENSION:	12,500 lbf (5,670 kgf / 55.60 kN)
OPERATING TIME:	Alkaline AA Cells 24 hours
WIRE ROPE:	Diameter 3/16 in (5 mm) – 1 in (25 mm)
ACCURACY:	Rated Accuracy $\pm 3\%$ of capacity
UNITS:	lbf, kgf, kN
RESOLUTION:	Standard: 2500 divisions
TWO-LINE LCD DISPLAY:	Primary Display (bottom) six, 0.7 in (18 mm) numeric digits Secondary Display (top) eight, 0.5 in (13 mm) numeric digits
FUNCTION KEYS:	Two programmable keys (user-defined) – F1, F2 (TEST, UNIT, PRINT, SCROLL, ACTFUN) Two permanent keys – POWER, ZERO
SETPOINTS:	Two dedicated setpoints for minimum and maximum allowable wire rope tension (LEDs for measurements outside of allowable range)
AUTO-OFF MODE:	Prolongs battery life by turning Power OFF after 15, 30, 45 or 60 minutes of no activity (user determined)
ENCLOSURE:	IP65 Powder-coated aluminum frame
CALIBRATION:	Up to eight (8) factory programmed wire rope calibrations
OPERATING TEMP:	-4°F to 122°F (-20°C to 50°C)
OPERATOR USE:	Outdoor
STORAGE:	Indoor
WARRANTY:	Two-year limited warranty

RICE LAKE
WEIGHING SYSTEMS

HEADQUARTERS

230 West Coleman Street
Rice Lake, Wisconsin 54868 - USA
Tel: (715) 234 9171 | Fax: (715) 234 6967
www.ricetake.com